

PAGEr™ Precast Gels – Instruction Protocol

Introduction

This protocol covers all formats of PAGEr™ Gold Precast Gels.

Precautions

- Before silver staining please see the recommendations on page 3 of this protocol or contact Technical Service.
- Wear gloves and use all safety precautions when handling PAGEr™ Gels.
- Please read the Material Safety Data Sheet (MSDS) for this product prior to use. MSDS's are available from Lonza Scientific Support, or www.Lonza.com.
- If you plan to dry your gel, please contact Scientific Support for recommended protocol.

Procedure

1. Cut open the pouch and remove the gel.
2. Rinse the gel cassette with distilled or deionized water.
3. Peel the tape off the bottom of the cassette.
4. Gently pull out the comb and place it aside so it can be used to separate the cassette plates at the end of the run.
5. Mount the cassette(s) into the electrophoresis apparatus so the printed side faces the outer (anode) buffer chamber. If running only one gel, mount an appropriate buffer dam. See pages 2 and 3 for chamber instructions.
6. Fill the buffer chambers with appropriate amounts of running buffer.
7. Rinse wells with 1X running buffer.
8. Load samples into the wells (use printed lane markings as guides). For best results, load 1X sample buffer in wells without samples. See page 2 for well loading volumes.
9. Attach the electrophoresis apparatus to the power supply.
10. Run gels at constant voltage following these guidelines:

<u>Gel</u>	<u>Voltage</u>
Tris-Glycine	125 V – 200 V
TBE	20 V/cm Interelectrode distance

NOTE: for optimal results with Tris-Glycine gels, 125 V is recommended.

11. When the dye front nears the bottom of the gel(s), the run is complete. Shut power off and remove gel(s).
12. Hold the cassette in one hand and use the comb to separate the plates as shown in the illustration right.
13. The gel will adhere to either the short or long plate. Hold the plate with the gel over an open container.

If the gel is adhered to the larger plate carefully insert thumb nail or a flat edged device (such as the comb teeth) through the plate's slot and gently push out the bottom of the gel; allow the gel to peel away and gently drop into the container. *If the gel is adhered to the smaller plate,* carefully use the comb or a spatula to loosen one lower corner of the gel; allow the gel to peel away and gently drop into the container.

NOTE: For best results, before removing the gel from the plate, remove well area and bottom lip of gel using a sharp spatula or razor blade. Use a chopping, straight up and down motion to prevent tearing the gel.

14. Fix, stain and destain or blot the gel as desired. If silver staining or blotting, please see recommended modifications on page 3.

Instructions for opening PAGEr™ Precast Gels:

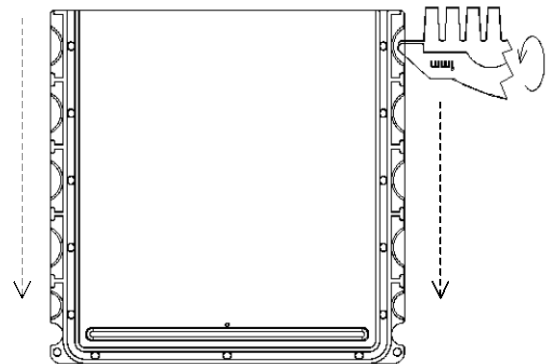

Step 1: Crack open cassette sides by inserting the comb tip into each of the notches around the cassette and twisting firmly. Starting with the notches at the top, move down each side of the cassette.

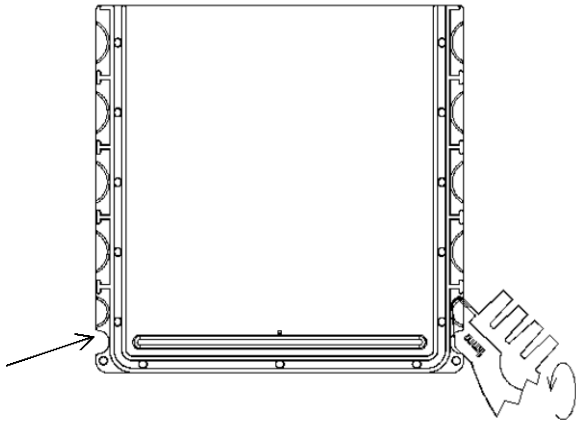

Step 2: After the sides are open, place the comb's slanted edge at a 45-degree angle between the plates at each bottom corner and twist firmly.

Step 3: Gently separate the two cassettes

Storage Conditions

PAGEr™ Precast Gels should be stored at 2°C-8°C. **Do not freeze.** Package contains gel buffer (0.02% sodium azide added as preservative).

Specifications

Cassette Dimensions	Thickness	Gel Dimensions (LxWxD)
9 x 10 cm L x W	0.49 cm	7.1 cm x 8.3 cm x 0.1 cm
10 x 10 cm L x W	0.55 cm	8.1 cm x 8.3 cm x 0.1 cm
Gel Matrix:	polyacrylamide	
Stacking Gel:	4% stacking gel (Tris-Glycine gels only)	
Well formats:	Tris-Glycine gels: 2D well, 8+1 well*, 10 well, 12 well, 16 well, 17 well* <i>*multichannel pipette compatible well formats</i>	
	TBE gels: 10 well, 12 well, 16 well	
Well Loading Volumes	Number of Wells	Well Volume
	8+1	≤30µl
	10	≤32µl
	12	≤20µl
	16	≤14µl
	17	≤14µl
	2D	≤550µl
Storage/Shelf Life:	PAGEr™ Gold Tris-Glycine & TBE Gels: 2°C-8°C for 3.5 months from manufacture	

Optimal Separation Ranges in PAGEr™ Gels

Tris-Glycine Gels	
Polyacrylamide	Size Separation Range
7.5%	50 kDa-200 kDa
10%	25 kDa-200 kDa
12%	20 kDa-100 kDa
15%	10 kDa-50 kDa
4-20%	5 kDa-200 kDa
10-20%	5 kDa-150 kDa
4-12%	25 kDa-250 kDa
8-16%	15 kDa-200 kDa
TBE Gels	
Polyacrylamide	DNA Separation Range
6%	75 bp-2000 bp
10%	30 bp-1000 bp
4-20%	10 bp-2000 bp

Buffer Types and Characteristics

PAGEr™ Gold Precast Gels use Tris-HCl or Tris-Borate buffer systems suitable for protein or nucleic acid electrophoresis respectively. PAGEr™ Gels for proteins are compatible with Tris-Glycine SDS running buffer for separation of denatured proteins and Tris-Glycine running buffer for separation of native proteins. PAGEr™ Gels are compatible with most commonly used sample buffers.

Tris-Glycine Gels (Tris-HCl buffer system)

Electrode Buffer (1X)	Sample Buffer (1X)
25 mM Tris Base	62.5 mM Tris-HCl, pH 6.8
192 mM Glycine	2% SDS*
0.1% SDS*	10% Glycerol
	0.01% Bromophenol Blue
	2.5% βME (2-mercaptoethanol)*

*Omit for native proteins

TBE Gels

Electrode Buffer (1X)	Sample Buffer (6X)
89 mM Tris Base	0.25% Bromophenol Blue
89 mM Boric acid	0.25% Xylene Cyanol
2 mM EDTA • 2H ₂ O	15% Ficoll® Type 400

Electrophoresis Chamber Compatibility

PAGEr™ Gels fit a variety of chambers. Some chambers require modifications. See Chamber Modification Instructions below.

	9 x 10 cm	10 x 10 cm
PAGEr™ Minigel Chamber	X	X
Novex® XCell II™		X
XCell SureLock® Mini-Cell		X
Bio-Rad® Mini-PROTEAN® II, 3, Tetra	X	
Bio-Rad® Ready Gel® Cell	X	
Hofer® Mighty Small (SE260)	X	X
Hofer® Mighty Small (SE250)	X	X
Hofer® Mighty Small (SE280)	X	X
Biometra® Mini V 8.10, Twin	X	
Sigma-Aldrich® Mini Techware	X [†]	X*
CBS Scientific-MGV system	X [†]	X*
Owl Separation Systems		X
FisherBioTech® - FB-VE10-1		X
FisherBioTech® - FB-VE12-1		X
Fisher EC 120-2	X	X
EC 120 mini vertical gel system	X	X

† (10 X 8 cm unit)

*(11.3 x 10 cm unit)

Chamber Modifications for Lonza PAGEr™ Precast Gels.

Bio-Rad® Mini-PROTEAN® II, Mini-PROTEAN® 3 or Mini-PROTEAN® Tetra Cell Ready Gel® Cell Systems

PAGEr™ 9 x 10 cm Gels

Remove the rubber gasket from the inner core. Replace the gasket in the reverse orientation into the unit so the flat side faces outward.

FisherBioTech® Vertical Minigel Protein System

FB-VE10-1 mini chamber

PAGEr™ 10 x 10 cm Gels

Request Lonza adaptor for FisherBioTech® FB-VE10-1 (Lonza part no. 59902). The Lonza adaptor for this chamber only works if the inner gasket is white. Replace black-plastic side spacer with Lonza adaptor. Use one on each side of the inner core.

For chambers with orange gaskets, call Lonza Scientific Support to request the appropriate spacers.

FisherBioTech® Vertical Minigel Protein System:

FB-VE12-1

PAGEr™ 10 x 10 cm Gels

Chamber comes with 2 sets of wedges. Use the thinner wedges for PAGEr™ Gels.

Hofer® Mighty Small (SE250)

PAGEr™ 9 x 10 cm or 10 x 10 cm Gels

Replace the buffer chamber with a 'Deep lower buffer chamber for the SE260', Amersham Pharmacia order number 80-6148-78. Pull the center core out from the SE250 base and place into the deep lower buffer chamber for the SE260. The extra depth of the SE260 chamber allows the lid to lock into place.

XCell SureLock® Mini-Cell

PAGEr™ 10 x 10 cm Gels

Request the Lonza spacer for the XCell SureLock® Mini-Cell chamber (Lonza part no. 59900).

To run one gel: Put the gel in the front of the chamber. Put the buffer dam on the back. Place the Lonza spacer between the buffer dam and the buffer core, on the side of the chamber with the gel tension wedge. Lock the gel tension wedge.

To run two gels: Put a gel on each side of the buffer core. Place the Lonza spacer between the gel and the buffer core, on the side of the chamber with the gel tension wedge. Lock the gel tension wedge.

Owl Scientific Penguin™ Model P8DS-1

PAGEr™ 10 x 10 cm Gels

Request Lonza adaptor for Owl Scientific Penguin™ chamber. The Lonza adaptor for the Penguin™ chamber only works if the inner gasket is white. Replace black-plastic side spacer with Lonza adaptor. Use one on each side of the inner core. For Owl chambers with orange gaskets, call Lonza Technical Support to request the appropriate spacers.

Western Blotting Recommendations

PAGEr™ Gels are compatible with standard blotting methods and have been optimized using semi-dry blotting systems and nitrocellulose membranes.

Ensure even contact between all layers of the blotting-stack system.

- Use a spatula or razor blade to remove the well area and bottom lip of the gel. Use a chopping, straight up and down motion to prevent tearing the gel.
- Gently roll out any air bubbles between each layer with a **wet** glass rod or pipette.
- Use enough transfer solution to wet the filter paper thoroughly, without over saturation. Blotting times will vary depending on the experimental conditions, apparatus, buffer, protein, etc. The times listed below serve as general guidelines when using a Tris-glycine-methanol transfer buffer.

Semi-dry System

- ~ 60 minutes for 10 kDa–100 kDa
- ~ 90 minutes for 100 kDa–300 kDa

Tank Blot System

- ~ 90 minutes for 10 kDa–100 kDa
- ~ 120 minutes for 100 kDa–300 kDa

- PAGEr™ Gels can be used with nitrocellulose (supported and unsupported) and PVDF membranes in both tank and semi-dry blot systems.
- Center the gel on the nitrocellulose or PVDF membrane. Occasionally, the gel will overlap the membrane and stick to the filter paper below. If this occurs, gently break the seal with scalpel.

Recommended Modifications for Silver Staining and gel drying

PAGEr™ Gold Gels

PAGEr™ Gold Gels are compatible with all Silver Stains.

For Pharmacia PlusOne Silver Staining kit, follow the manufacturers instructions with the following adjustments:

- Fixation Step: Increase time to two, 20 minute washes.
- Sensitizing Step: Decrease glutaraldehyde (25% w/v) amount to 1.0 ml per 250 ml of solution.
- Washing Step: Increase time to three, 10 minute washes.

PAGEr™ Gold Gels are compatible with all other staining chemistries. For optimal sensitivity and ease-of-use, use SYPRO® Protein Gel Stains.

Ordering Information

PAGEr™ Gold Gels are available in a variety of single and gradient gel concentrations & well configurations.

For more information contact Scientific Support or visit www.lonza.com.

Related Products for Protein Separation

ProSieve™ Color Protein Markers
ProSieve™ Protein Markers
AccuGENE™ Tris-Glycine Buffer
AccuGENE™ Tris-Glycine SDS Buffer
SYPRO® Ruby Protein Gel Stain
SYPRO® Red Protein Gel Stain
SYPRO® Tangerine Protein Gel Stain
SYPRO® Ruby Protein Blot Stain
PAGEr™ Minigel Chamber

For Research Use Only

SYPRO is a trademark of Molecular Probes, Inc., Bio-Rad, Ready Gel and Mini-PROTEAN are registered trademarks of Bio-Rad Laboratories, Inc., FisherBioTech is a trademark of Fisher Scientific Company, LLC, Hoefer is a trademark of Hoefer, Inc., Ficoll is a trademark of GE Healthcare Bio-Sciences AB, NOVEX, XCell II, and XCell Surelock are trademarks of Life Technologies Corp., Penguin is a trademark of Thermo Fisher Scientific Inc., Biometra is a trademark of Biometra Biomedizinische Analytik GmbH. Sigma-Aldrich is a trademark of Sigma-Aldrich Biotechnology L.P. All other trademarks herein are marks of the Lonza Group or its affiliates.

Copyright ©2008 Lonza Rockland, Inc.
All rights reserved